

1. Potential burnt or explosion of battery pack charged by serially charging technique

Most of the Li-ion/polymer chargers on the market are using serial charging technique to charge the Li-xx batteries. The serial charging technique is circuit connected as Drawing 1 indicated. In case, if one of the cell of the battery pack is defective & can't be full charged up to its defined full voltage level, the other good cell or (cells) will then be over charged. Take cells in drawing 1 for example, if cell A is defective & can only be charged up to 2.8 v or lower, the good cell B will then be overcharged up to $4.2 + (4.2-2.8) = 5.6$ v or higher. A Li-xx battery can only stand its maximum voltage up to 4.6~4.9. If it is over 4.9 v, it will be either burnt or exploded. That is why lots of Li-xx battery packs burnt or exploded during charging process.

2. Parallel charging technique of our charger-circuit connected as drawing 2 Dotted Lines

Instead of charging all cells of the battery pack serially, our charger is designed to control charging process of each cell of the battery pack independently or in parallel. It will completely eliminate the interference between cells of the battery pack during charging process. It will also reduce and avoid the possibility of burnt or explosion caused by a problem battery pack with defective or unbalance capacity cell inside.

3. Special battery pack package style is required

The battery packs going to be charged on this charger should be packed as drawing 2 indicated. Every battery pack should have one additional charge connector. By connecting this connector to the respective charger out-put port, you are now doing a safety charging to your Li-xx battery packs.

4. Life of the Li-xx battery packs

When stay no use, the Li-xx battery will have a self-discharge process. It will be fatal dead if its voltage is discharged down to 2.4 v or lower. So that it is strongly recommended to have all Li-xx batteries being charged once every 3 months.

5. The number of cells of the battery packs being charged by this charger is limited at 4 cells maximum. If it is over 4 cells plugged on the charger at the same time, there will be a big possibility to damage the battery cells being charged. **That is the charger is not allowed to charge a 3 cells pack & a 2 cells pack at the same time, or a 4 cells pack & other battery packs at the same time.**

6. Warning

Although by connecting serial charge adaptors (5-pin to 2 pin, 4-pin to 2-pin or 3-pin to 2-pin adaptors) to the charger out-put ports, the charger can be used as a serial charging charger, which will then be able to charge the common packed batteries. However, it is strongly recommended not to do so since it may cause disaster as explained in para 1 of this special instruction. The manufacture shall not responsible for such miss-use of the charger.

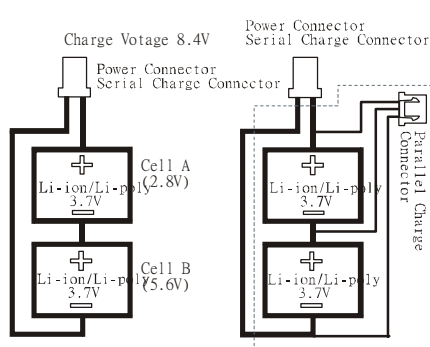

Drawing 1

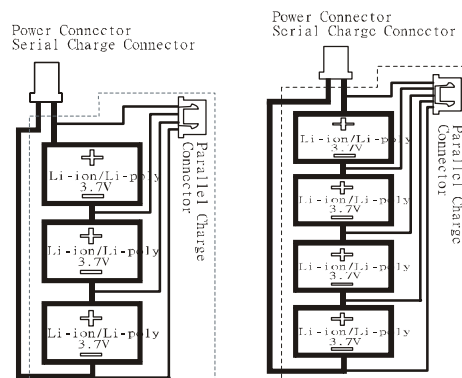

Drawing 2

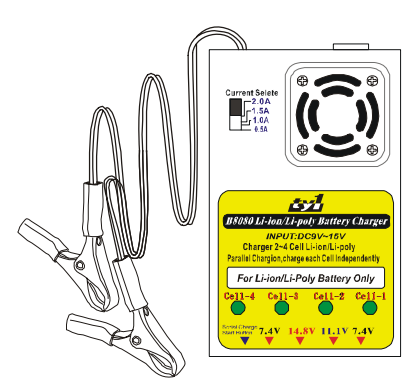

Drawing 3

Serial charge operation instruction (Not recommended, see warning of the special instructions)

1. Connecting charger to power source, all LED will light on in green color, indicating that the charger is in good status & ready to use. Set Current Select to suitable position; 0.5A --- For cells with 360 mAh or higher, 1.0A --- For cells with 750 mAh or higher, 1.5A --- For cells with 1200 mAh or higher, 2A --- For cells with 1800 mAh or higher.
2. Select correct charger out - put ports (connectors) for the battery packs to be charged. There are 4 out-put ports of the charger, the port labeled 7.4v is for 1 or 2 cells (3.7v x 2), the port labeled 11.1v is for the 3 cells battery pack, the port labeled 14.8v is for the 4 cells battery pack.
3. Connect the serial charge adaptor to the relative charger out-put ports. P/N B80514 serial charge adaptor matches to 7.4V out-put port for 2 ea single cell battery pack . P/N B80515 serial charge adaptor matches to 7.4V out-put port for 1 ea 2-cell battery pack. P/N B80516 serial charge adaptor matches to 11.1V out-put port for 3-cell battery pack. P/N B80517 serial charge adaptor matches to 14.8V out-put port for 4-cell battery pack.
4. Connect battery packs to the relative serial charger adaptors & push down the start button. The charger will start charging. During charging process, The relative LED of the charger will turn into red.
5. While start charging, the number of the LED which changes color into red shall be the same as the number of the cells of the battery pack. For example, a 2 cells battery pack will have 2 LED in red color during charging, a 3 cells battery pack will have 3 LED in red color during charging, a 4 cells battery pack will have 4 LED in red color during charging. If the number of the lighted LED is not the same as the number of the cells of the battery packs, re-push down the serial start button again will make both numbers the same. If it's not be able to get the both numbers at the same figure after push down the serial button again, the battery pack is damaged and no longer be used normally.
6. When the battery pack is fully charged, all relative LED colors will change from red to green. It indicates the battery pack is fully charged and ready to use any time.
7. The number of cells of the battery packs being charged by this charger is limited at 4 cells maximum. If it is over 4 cells plugged on the charger at the same time, there will be a big possibility to damage the battery cells being charged. **That charger is not allowed to charge a 3 cells pack & a 2 cells pack at the same time, or a 4 cells pack & other battery packs at the same time.**

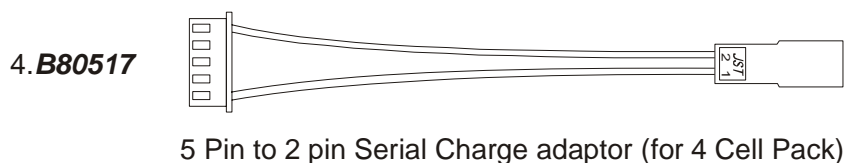
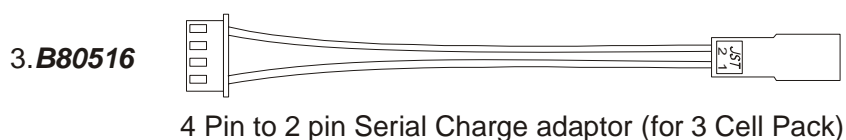
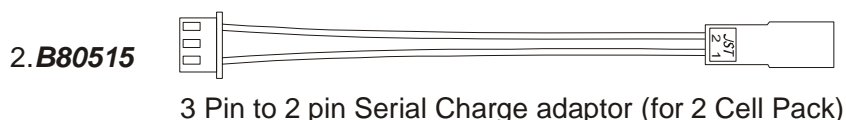
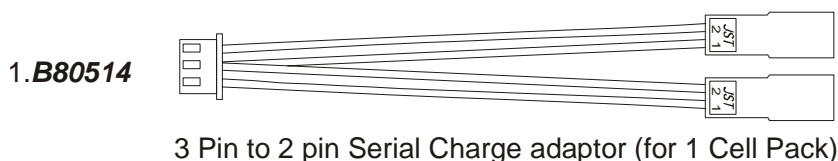

 **HOBBY SQUADRON LTD.**

No.209,Jinghe E. St.,Beitun District,
Taichung, City 40642, Taiwan (R.O.C.)
E-Mail:steve@ty1.com.tw
<http://www.ty1.com.tw>
TEL:886-4-24380007
FAX:886-4-24377500